



DS-300

# Vertical Axis Wind Turbine

## User Manual



**Hi-VAWT Technology Corporation**  
**[www.hi-vawt.com.tw](http://www.hi-vawt.com.tw)**

**Version 2.**

## Table of Contents

WARNING .....	5
DISCALIMER.....	7
1. Safety Precautions .....	8
1.1 Mechanical Hazards .....	9
1.2 Electrical Hazards .....	9
1.3 Assembly.....	10
1.4 Installation .....	11
1.5 Operation .....	12
2. Introduction.....	12
2.1. DS-300 Specification .....	14
2.2. DS-300 Standard Packing .....	15
2.4. DS-300 Wind Power System Controllers .....	17
2.5. DS-300 Optional Parts .....	18
3. Preparation of Assembly and Installation .....	18
3.1 Selecting Location.....	18
3.2 Mast Preparation.....	19
3.3 Foundation Guide for DS-300 .....	23
3.3.1 Ground Foundation.....	24
3.3.2 Roof Foundation.....	26
4. DS-300 Assembly and Installation.....	29
4.1 Tools Required for Assembly and Installation .....	29
4.2 DS-300 VAWT Assembly .....	30
4.3 DS-300 Installation.....	33
5. Wiring.....	38

5.1	General Information.....	38
5.2	DS-300 Wire Size.....	38
5.3	DS-300 Wiring Diagram.....	39
5.4	PV Charging.....	43
5.5	Grounding.....	43
5.6	Fusing.....	43
6.	Warranty.....	45

## ***Table of Figures***

<i>Figure 2-1 General View of the DS-300 VAWT System .....</i>	<i>13</i>
<i>Figure 2-2 DS-300 Standard Packing Contents .....</i>	<i>16</i>
<i>Figure 2-3 System Controllers.....</i>	<i>17</i>
<i>Figure 3-1 Dimension for Mast .....</i>	<i>21</i>
<i>Figure 3-2 Optional Mast Design .....</i>	<i>23</i>
<i>Figure 3-3 Ground Foundation Construction Reference .....</i>	<i>25</i>
<i>Figure 3-4 Foundation for Roof Installation Reference.....</i>	<i>27</i>
<i>Figure 4-1 Required Tools for Assembly and Installation.....</i>	<i>29</i>
<i>Figure 4-2 DS-300 Assembly Procedures - 1 .....</i>	<i>30</i>
<i>Figure 4-3 DS-300 Assembly Procedures - 2 .....</i>	<i>32</i>
<i>Figure 4-4 DS-300 Assembly Procedures - 3 .....</i>	<i>33</i>
<i>Figure 4-5 DS-300 Installation Procedures - 1 .....</i>	<i>34</i>
<i>Figure 4-6 DS-300 Installation Procedures - 2 .....</i>	<i>35</i>
<i>Figure 4-7 DS-300 Installation Procedures - 3 .....</i>	<i>36</i>
<i>Figure 4-8 DS-300 Installation Procedures - 4 .....</i>	<i>37</i>
<i>Figure 5-1 Wiring Diagram for Wind Charge Controller (WG0400) .....</i>	<i>40</i>
<i>Figure 5-2 Wiring Diagram for Wind/PV Hybrid Controller (WG0400/RC10-II)</i> <i>.....</i>	<i>42</i>

***Table Index***

*Table 2-1 DS-300 Technical Specification.....14*  
*Table 2-2 DS-300 Components.....15*  
*Table 5-1 Wire Sizing Reference .....39*  
*Table 5-2 DS-300 Wiring Size Reference (WG0400).....41*

## **WARNING**

THIS USER' MANUAL PROVIDES INSTRUCTIONS AND GUIDELINES FOR ASSISTANCE WITH ASSEMBLY AND INSTALLATION OF THE HI-VAWT'S DS-300 VERTICAL AXIS WIND TURBINE. ALTHOUGH THE DS-300 VAWT HAS BEEN DESIGNED AS EASY AS POSSIBLE FOR THE INSTALLATION, IT STILL REQUIRES SPECIALIZED SKILLS, TOOLS AND EXPERIENCE AS WELL. FOR THE PURPOSES OF ASSEMBLING, INSTALLING, OPERATING AND MAINTAINING THE DS-300 VAWT, WE ASSUME THAT PERSONNEL WHO INVOLVED IN THE WHOLE PROCESSES HAS THE SKILLS, TOOLS REQUIRED TO DO SO. NO ONE SHOULD ATTEMPT TO ASSEMBLE, INSTALL, OPERATE AND MAINTAIN THE DS-300 VAWT SYSTEM WITHOUT THE NECESSARY SKILLS, EXPERIENCE, TOOLS AND SAFETY EQUIPMENT.

DISASSEMBLING THE PARTS FROM ORIGINAL IS RESTRICTED. ALL PRE-ASSEMBLED PARTS ARE FACTORY ADJUSTED, BALANCED AND TESTED. HI VAWT TECHNOLOGY CORPORATION ASSUMES NO WARRANTIES AND LIABILITIES OF DOING SO.

HI-VAWT TECHNOLOGY CORPORATION (Hi-VAWT) ASSUMES NO DIRECT OR CONSEQUENTIAL LIABILITY IF FAULTY OR DANGEROUS ASSEMBLING, INSTALLATION OR MAINTENANCE PRACTICES ARE PERFORMED. PLEASE CONTACT HI-VAWT TECHNOLOGY CORPOATION IF CONSULTATION OR ASSISTANCE IS REQUIRED.

HI-VAWT RECOMMENDS THE DS-300 VAWT SYSTEM SHOULD BE SITED ACCORDINGLY IN AN EXCLUSION ZONE WITH CONTROLLING PUBLIC ACCESS. APPROPRIATE WARNING SIGNS SHOULD BE PLACED ON THE OPERATING SITE.

THE DS-300 SHOULD NOT BE INSTALLED NEAR UNPROTECTED POWER LINES, TREES OR ANY OBJECTS THAT WOULD POSSIBLY CAUSE THE HAZARDS OF THE OPERATION.

Hi-VAWT Technology Corporation

No. 168, Jhu-lin 1<sup>st</sup> Rd., Lin-kuo town, 244, Taipei County, Taiwan

Tel: +886-2-8601-4373

Fax: +886-2-8601-1263

E-Mail: [sales@hi-vawt.com.tw](mailto:sales@hi-vawt.com.tw)

Website: [www.hi-vawt.com.tw](http://www.hi-vawt.com.tw)

## **DISCALIMER**

Although Hi-VAWT recommends reading the entire manual thoroughly prior to assembly and installation to ensure proper performance and safety, this manual is intended as a guide only. It should not be considered as a replacement of professional services or as a definitive text for assembling and installing the DS-300 VAWT systems.

Hi-VAWT makes no warranties by either expressed or implied that the information contained in the manual is accurate or complete. Hi-VAWT Technology Corporation makes no warranties of fitness for a particular purpose and /or site. Hi-VAWT will not be responsible for any direct or consequential damages, or an incidental expense.

All instructions, figures and diagrams are believed to be accurate at the time of printing. The success and safety in working with tools depend greatly on individual accuracy, skill and caution. For this reason, Hi-VAWT is not able to guarantee the result of any contained procedure in the manual, nor can they assume responsibility for any damage to property or injury to persons resulting from procedures contained in this manual. Persons who engage in the procedures take their own responsibility and risk.

Actual power resources and selected site conditions will highly affect the energy production, which will vary with wind turbine maintenance, surrounding environment, therefore, Hi-VAWT makes no representation or warranties regarding energy production.

Wind generators, like other sources of electrical power, Must be installed following the guidelines established by local and national regulations. Please consult a local electrical contractor for details and regulations.

The information and all specifications contained within this manual are subject to change without notice.



# 1.Safety Precautions

The DS-300 is designed with user safety in mind. However, there are inherent dangers involved with any structural, mechanical and electrical equipment, the surrounding environment as well.

Safety must be the primary concern as you plan the location, assembly, installation and operation of the DS-300 VAWT. At all times be aware of electrical, mechanical and rotor blade hazards.

This Owner’s Manual contains important instructions, guidelines and safety notes that should be followed during the installation and maintenance of the Hi-VAWT’s DS-300 VAWT.

Please read thoroughly and follow the instructions in this USER’S MANUAL before assembling and installing the DS-300 VAWT.

Please refer to the following symbols which are used throughout this manual to indicate potentially dangerous situations, important safety instructions or important notes for you to know.



*This **WARNING** symbol indicates a possible dangerous condition.*

*Please use extreme caution when processing the procedure.*



*This **CAUTION** symbol identifies an improper operation that could result in critical safety issue or damage to the system controller or related devices.*



*The **NOTE** symbol describes an important procedure or issue for you to know to properly and safely operating the device.*

## 1.1 Mechanical Hazards

Rotating blades present the most serious mechanical hazard. The DS-300's rotor blades are made of very strong anodized aluminum. Some edge of the blades are sharp, please do not touch those sharp blades. Even though, with the built-in airfoil, the edges of those blades are not as sharp, they still will cause serious injury when they start rotating, even at low speed.



- NEVER TOUCH THE RUNNING ROTOR.
- NEVER TRY TO STOP THE RUNNING ROTOR BY HAND.
- DO NOT INSTALL THE DS-300 VAWT SYSTEM WHERE ANYONE CAN APPROACH THE PATH OF THE BLADES.
- AVOID ANY OBJECTS TOUCHING THE RUNNING ROTOR.

## 1.2 Electrical Hazards

The DS-300 VAWT System is equipped with sophisticated generator and designed to provide protection from electrical dangers.

Heat in wiring systems is often a result of too much current flowing through and undersized wire or through a bad connection. It is important to follow the suggested wire-sizing chart to ensure a safe electrical system

The battery, if applied, should never be short-circuited as it will result a danger of setting the battery and cable on fire. In order to

avoid the threat and protect the cabling, fuses should be installed in the lines connecting to the battery.

 **WARNING**

- WIRING CABLE WITH INSUFFICIENTLY DIMENSION CROSS SECTION CAN CAUSE ELECTRICAL FIRE.
- NEVER SHORT-CIRCUIT THE BATTERY IF APPLIED.

### 1.3 Assembly

The DS-300 VAWT System is designed in “All Most Ready to Use” format and shipped with factory pre-assembled packing. The only assembly work required is Darrieus blades assembly. This user’s manual will guide you through the assembly procedures with detailed illustrations.

 **NOTE**

- Please carefully read the assembly instructions in this manual before proceeding.
- It is important to have a suitable working environment for performing the assembly tasks.
- Refer to the suggested list of tools required for the assembly and have all of them ready before proceeding.

 **WARNING**

- PLEASE ALWAYS KEEP SAFETY IN MIND WHILE PERFORMING THE ASSEMBLY PROCEDURES.
- ALWAYS WEAR SAFE HELMET AND GLOVES!

## 1.4 Installation

A fall from the height at which a wind turbine is ordinarily mounted will often result in death or serious injury. Therefore whenever practicably carry out as much work as possible on the wind turbine at ground level. If it is necessary to work on the installation at such height then use an appropriate access system such as a mast that is designed to carry the load of a person; a man-rated winch or rope access system; a hydraulic lift or other safe working platform. Wear appropriate safety equipment and make the general working area as tidy and safe as possible. Work during the daylight on windless days. Above all else think carefully about what you need to do and plan your work carefully, have all the tools and equipment ready before your start.

### CAUTION

- Installation procedures should be performed as much as possible at ground level.
- Use safety harnesses, safe helmets, gloves, etc.
- Make sure that all batteries, if applied, are disconnected from the system throughout the installation process.
- The DS-300 generator should be short-circuited to prevent unintended wind turbine rotating during the shipment. Please install the extension cable on the ground level and keep it short-circuited throughout the installation process.
- Please keep the rotor straight up or lie on the support stands at all-time during the installation process to prevent the blades twisted or lost balance.
- Please perform the installation at a calm and windless day.

## 1.5 Operation

Please check the support structures, blades and electrical system on regular basis.

- Even though the rotor blades are very strong, however, if they come in contact with a solid object, they can be damaged or even broken.
- When perform routine inspections, or at anytime you must approach the path of the blades, please disconnect the power leads from the batteries and short-circuit the wind turbine output leads (use the Stop Switch after installation or tie the output leads together) to stop the rotor blades from rotating. The DS-300 is designed to be shut down through the use of stop switch (brake switch).
- NEVER APPROACH THE TURBINE DURING OPERATION.

## 2. Introduction

The DS-300 is a hybrid Vertical Axis Wind Turbine (VAWT) system which combines drag-based design and lift-based design. It incorporates an S-type of Savonius rotor and three airfoil blades of egg-beater shape Darrieus to maximize the output performance.

The following Figure 2-1 shows a general view and major components of the DS-300 VAWT System.

**Figure 2-1 General View of the DS-300 VAWT System**

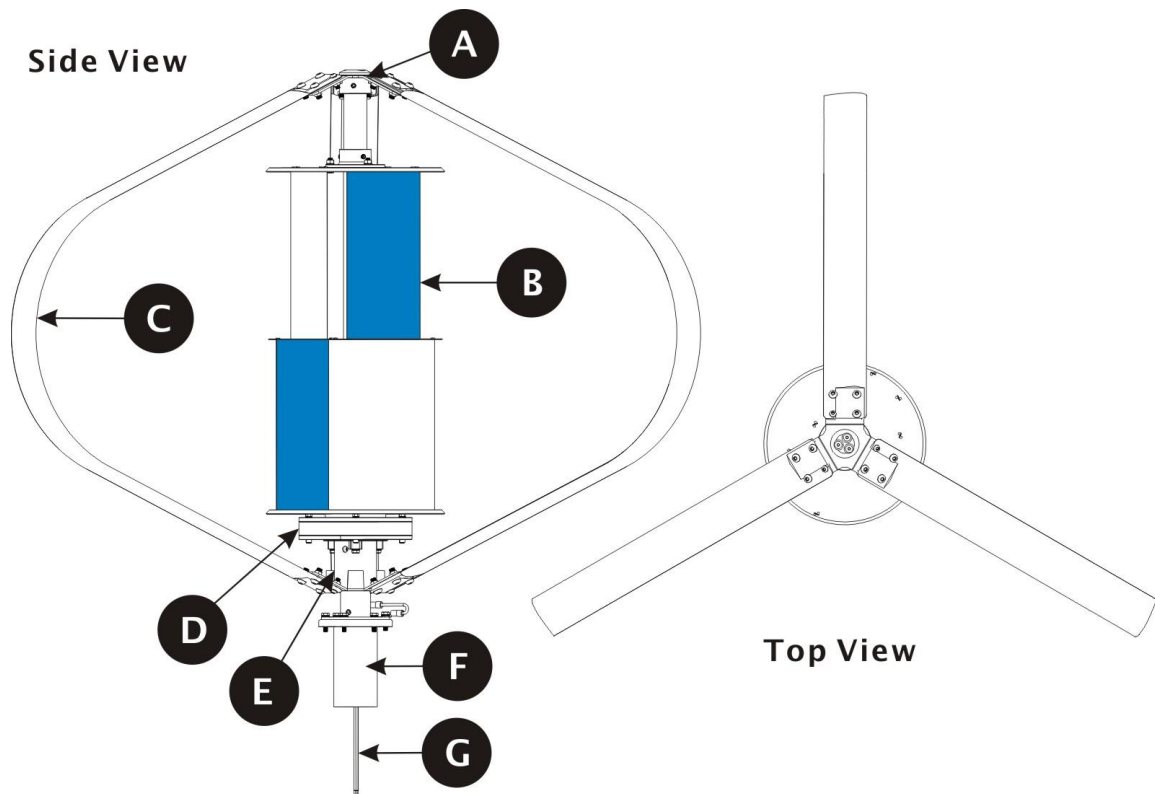

Parts	Description
<b>A</b>	Upper Darrieus Blades Connector.
<b>B</b>	S-Type Savonius.
<b>C</b>	3 Darrieus blades with built-in airfoil.
<b>D</b>	3-Phase, Direct Drive, Weather Sealed, Mechanically Integrated Permanent Magnet Generator.
<b>E</b>	Lower Darrieus Blades Connector.
<b>F</b>	Damper.
<b>G</b>	3-Phase R-S-T Generator Wires.

## 2.1. DS-300 Specification

The following table shows the technical specification of the DS-300 Wind Turbine.

*Table 2-1 DS-300 Technical Specification*

General Dimension	
<b>Rotor Diameter:</b>	1,245 mm
<b>Height:</b>	1,060 mm
<b>Weight:</b>	25.5 Kgs
Blades	
<b>Number of Blade:</b>	3
<b>Blade Material:</b>	Anodized Aluminum
Operation Mode	
<b>Cut-In Wind Speed:</b>	<3 m/s
<b>Cut-Out Wind Speed:</b>	15 m/s
<b>Survival Wind Speed:</b>	60 m/s
Safety Mechanism	
<b>Over Speed Braking:</b>	Yes. (Setup by Power Controller)
<b>Manual Brake:</b>	3-phase short-circuit Switch
Generator	
<b>Type:</b>	AC, Direct Drive, Weather Sealed, 3-Phase Synchronism PMG.
<b>Rated Output:</b>	300 W @ 13.5 m/s
Mounting	
<b>Foundation Mounting:</b>	Min. Height above ground: 3 meters.
<b>Roof Mounting:</b>	Min. Height above roof: 2 meters.
<b>Bedplate Mounting:</b>	Used where deep excavation cannot be applied
Warranty	
<b>Limited Warranty:</b>	1 year on components.

## 2.2. DS-300 Standard Packing

Please check all components you receive from the shipment with the packing list that comes with the purchase invoice or the enclosed parts list in the shipment. Ensure that you receive all standard components or parts for the DS-300 accordingly. If any missing parts from the original packing, please contact Hi-VAWT Technology Corporation for replacement.

Table 2-2 shows the standard packing of DS-300 VAWT System. Please also refer to Figure 2-2 for part locations. Detail assembly instructions will be discussed in the *Chapter 4 - Assembly and Installation*.

**Table 2-2 DS-300 Components**

Labels	Description	Quantity Included
<b>A</b>	Anodized Aluminum Blade (Assembly Needed)	<b>3</b>
<b>B</b>	Pre-assembled Components	<b>1 Set</b>
1	Upper Blades Connecting Plate	<b>1</b>
2	S-Type Savonius	<b>1</b>
3	Vertical Axis	<b>1</b>
4	300W PM Generator	<b>1</b>
5	Lower Blades Connecting Plate	<b>1</b>
6	R.S.T. Generator Wiring Cables	<b>3</b>
7	Mast Connector with Damper	<b>1</b>



8	Wind Turbine Surge Wire (Connected between Damper and Flange of the Mast)	1
<b>C</b>	Bolt Sets	
1	M10 x 25mm Button Hex Head Bolts and Nuts (Set)	18
2	M8 x 25mm Button Hex Head Bolts and Nuts	6
3	M8 x 30mm Hex Head Bolts/Washers	6
7-1	Set Screw M10 x 10mm	1
7-2	Socket Countersunk Head Cap Screw M5 x 16mm	2
8-1	M10 x 20mm Hexagon Socket Head Bolt and Nut (Set)	1

**Figure 2-2 DS-300 Standard Packing Contents**

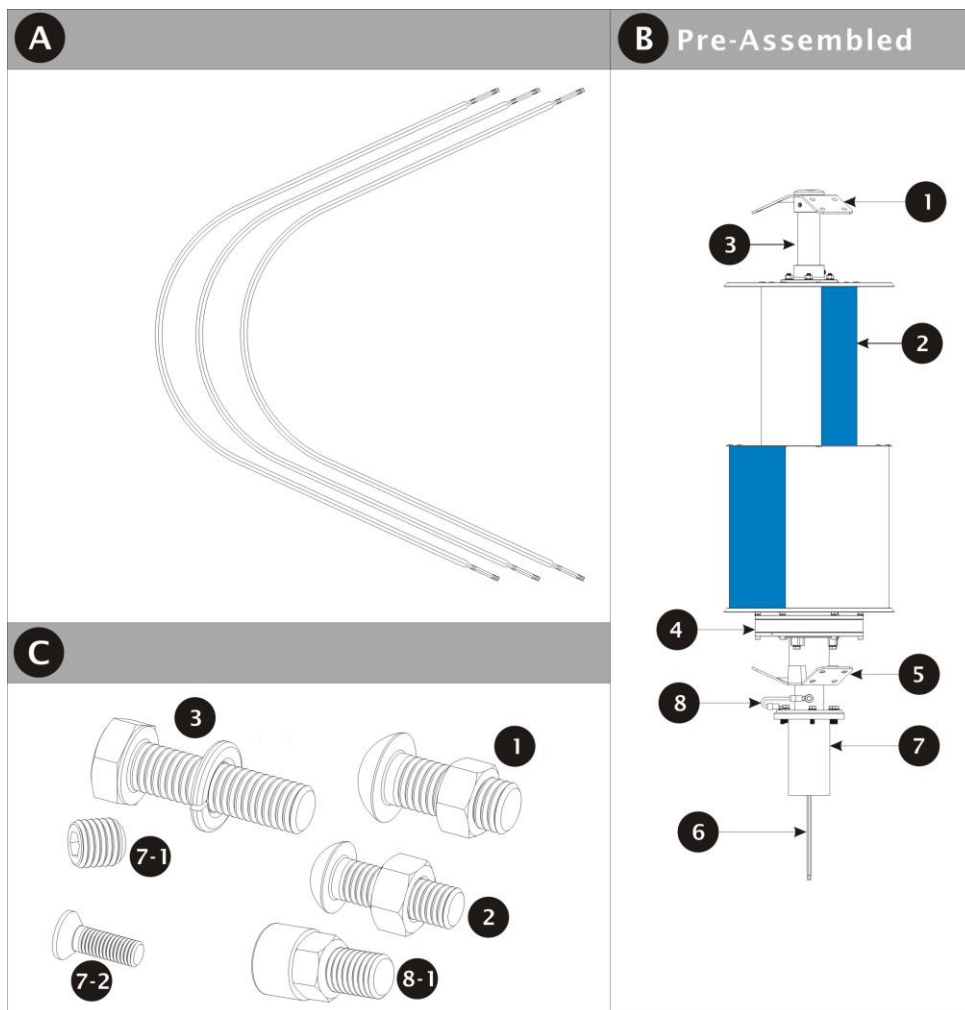

## 2.4. DS-300 Wind Power System Controllers

The standard DS-300 VAWT System is also alternatively packed with two types of wind power system controllers, either WG0400 12V/24V Wind Charge Controller or WG0400 12V/24V w/RC10-II Wind Power/PV Hybrid Controller, at user's choice. The descriptions and specifications of both WG0400 (12V/24V) and RC10-II System Controllers are detailed in their user manuals respectively.

Figure 2-3 lists the standard packing for DS-300 Wind Power System Controllers.

*Figure 2-3 System Controllers*

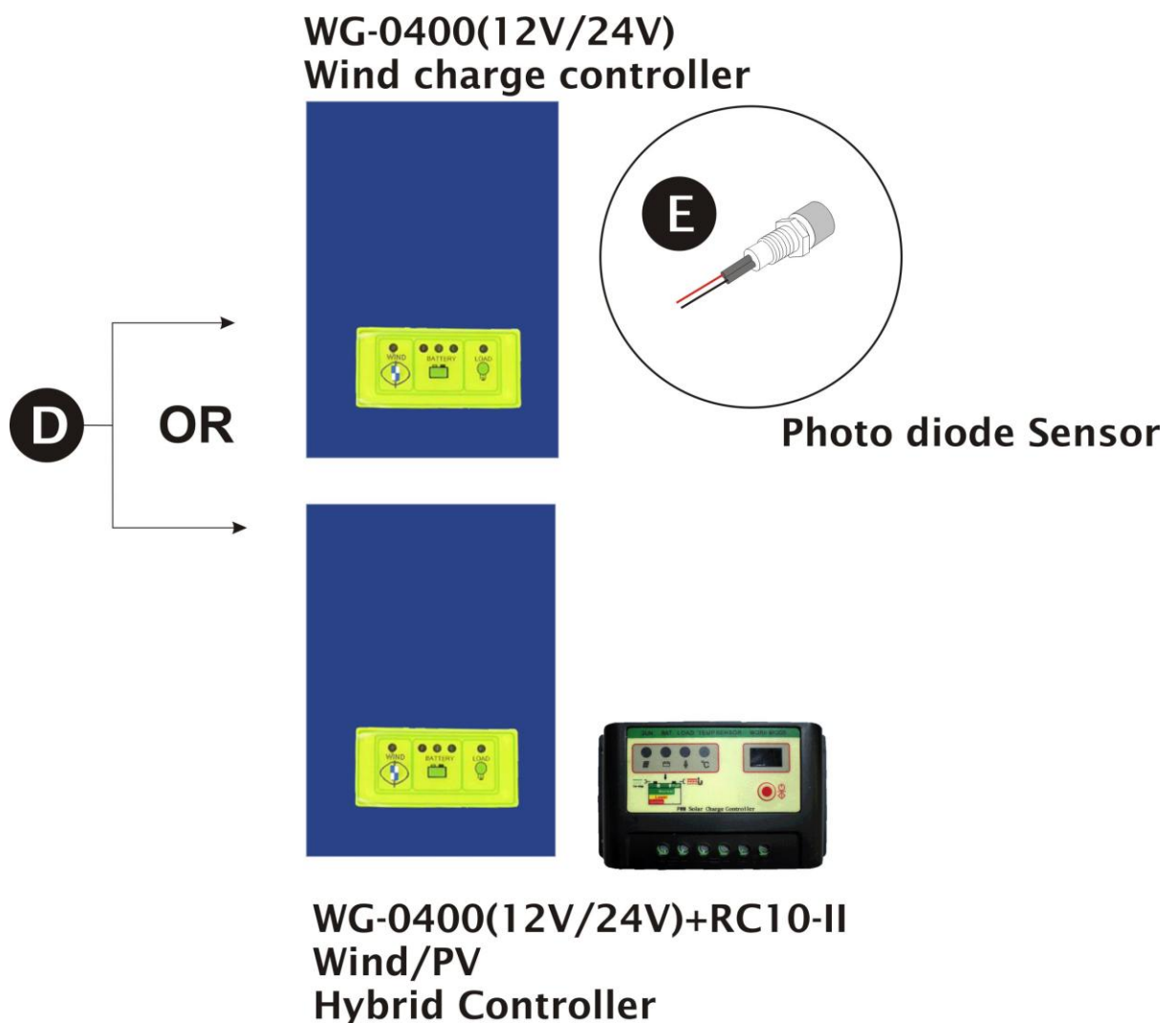

## 2.5. DS-300 Optional Parts

This DS-300 VAWT System is designed with simplicity in mind, so there are just a few parts needed which all included in the standard package. Concerning the shipping cost and different applications applied by customers, the required mounting mast to setup the DS-300 Wind Turbine is not included in the standard package. It would be an optional part based on customer's choice.

The detail description of the mounting mast will be explored in Chapter 3.

# 3. Preparation of Assembly and Installation

Before going through the DS-300 VAWT System installation procedures, please double check parts included in the package. Prepare all required tools and equipments accordingly and have them ready on hands. More importantly, all safety issues have been well thought and followed.

## 3.1 Selecting Location

The DS-300 Wind Turbine is designed with flexibility to fulfill user's applications. It can be installed along the street, sea shore, on the mountain, in the city, urban area, or just right on top of the roof of the building. The major key factor of affecting the performance of DS-300 Wind Turbine for all proposed applications is the location of optimizing wind energy.

### NOTE

We assume that the proposed site of installing the DS-300 VAWT System has been well evaluated by users themselves for optimizing the wind energy environment before any installing procedures performed.

## **WARNING**

- DO NOT install the DS-300 VAWT System at a site where anyone can easily approach the rotating blades.
- DO NOT install the DS-300 VAWT System at a site surrounded by obstructions. For example, Trees, power lines, etc.
- DO NOT install the DS-300 VAWT System at a site with improper structure to hold the DS-300 System.

## **CAUTION**

- Always follow your local regulations, codes about restrictions applied to such system installation.
- Always have your DS-300 grounded to avoid the lightning strike.
- Perform the installation of the DS-300 VAWT System in a calm and windless day.
- Perform all required assembly for the DS-300 VAWT System at ground level.

### **3.2 Mast Preparation**

As mentioned before, shipping charge of the mast made by Hi-VAWT will be costly. If you prefer making your own mast for DS-300 VAWT System rather than purchasing from Hi-VAWT, we will show you here how the mast can be made by your local supplier.

In the Figure 3-1, the Mast Specification was originally designed and tested on the DS-300 VAWT System. It has been approved and applied as the standard DS-300 VAWT System. It is important to follow the diameters shown in Figure 3-1 for Mounting Flange and Mast of the DS-300 VAWT System.

 **CAUTION**

- Please carefully check the structure of the building if you are going to install DS-300 VAWT System on the roof. Make sure the structure is strong enough to endure DS-300 VAWT System in terms of total weight, impact from gusty wind or earthquake, etc. Hi-VAWT Technology Corporation suggests the length of the mast is 2 meters for the roof installation and 3 meters for the ground.
- Carefully check the surrounding area when determines the length of the mast. Avoid any existing objects that affect the performance of wind energy or cause hazards.

The following Figure 3-1 shows the diagram for making the mast.

Figure 3-1 Dimension for Mast

**A** Mounting Flange

t=10

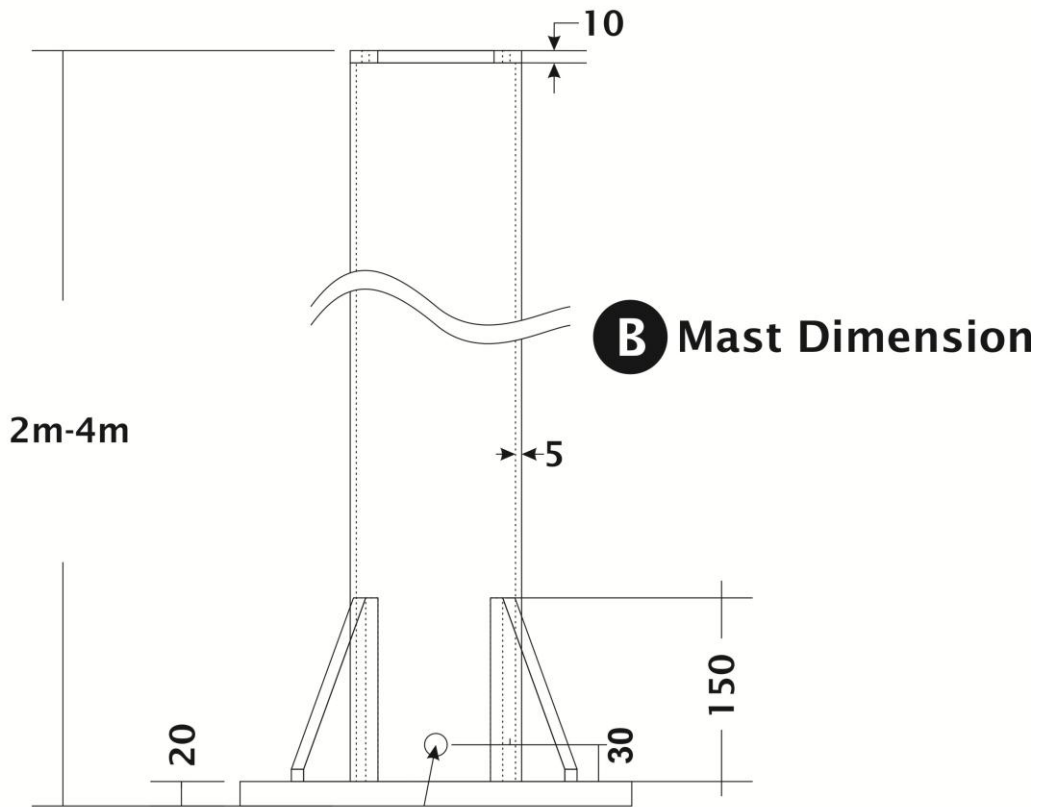

**B** Foundation Plate

Ø18.5

Unit: mm

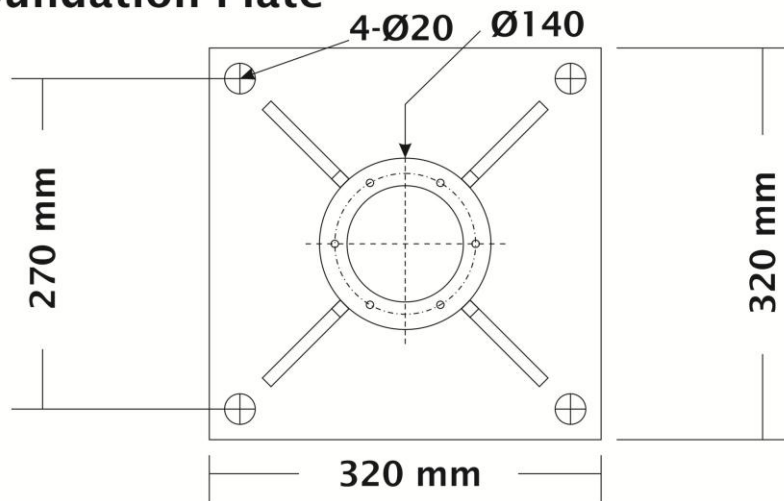

<p style="text-align: center;"><b>A</b></p>	<p>This portion shows the dimension of the mounting flange which should be welded on top of the mast for connection with the DS-300 VAWT System.</p> <ul style="list-style-type: none"> <li>• Flange Inner Dia. = <math>\varnothing</math>95mm</li> <li>• Flange Outer Dia. = <math>\varnothing</math>140mm</li> <li>• 6 - <math>\varnothing</math>8mmxP1.25 Tapped bolt holes on PCD <math>\varnothing</math>115 mm (60° each)</li> <li>• Flange thickness = 10mm</li> </ul>
<p style="text-align: center;"><b>B</b></p>	<p>Mast Dimension:</p> <ul style="list-style-type: none"> <li>• Prototype Design material: 140mm x 5m/m galvanized steel pipe.</li> <li>• Mast Outer Dia. = <math>\varnothing</math>140mm</li> <li>• Mast Inner Dial. = <math>\varnothing</math>120mm</li> <li>• Standard Length of the Mast = 3m</li> <li>• Mounting flange welded on the top of the Mast.</li> <li>• Foundation Plate welded under the bottom of the Mast with 4 support ribs (t=10).</li> <li>• Drill a18.5mm diameter hole at 30mm above the bottom of the mast. This hole is reserved for wiring cable exit. If an underground conduit is applied in the concrete foundation, then ignore this exit.</li> </ul>
<p style="text-align: center;"><b>C</b></p>	<p>Foundation Plate Dimension:</p> <ul style="list-style-type: none"> <li>• 320mm x 320mm</li> <li>• Thickness = 20mm</li> <li>• 4 x <math>\varnothing</math>25mm bolt holes on 270mm x 270mm.</li> <li>• 4 x 10mm in thickness of support ribs</li> </ul>

Figure 3-2 shows an optional design of the mounting mast. You may use hinge type mechanism at one side of the foundation plate to make an easy way to access the DS-300 by lowering down or lifting up the mast.

**Figure 3-2 Optional Mast Design**

---

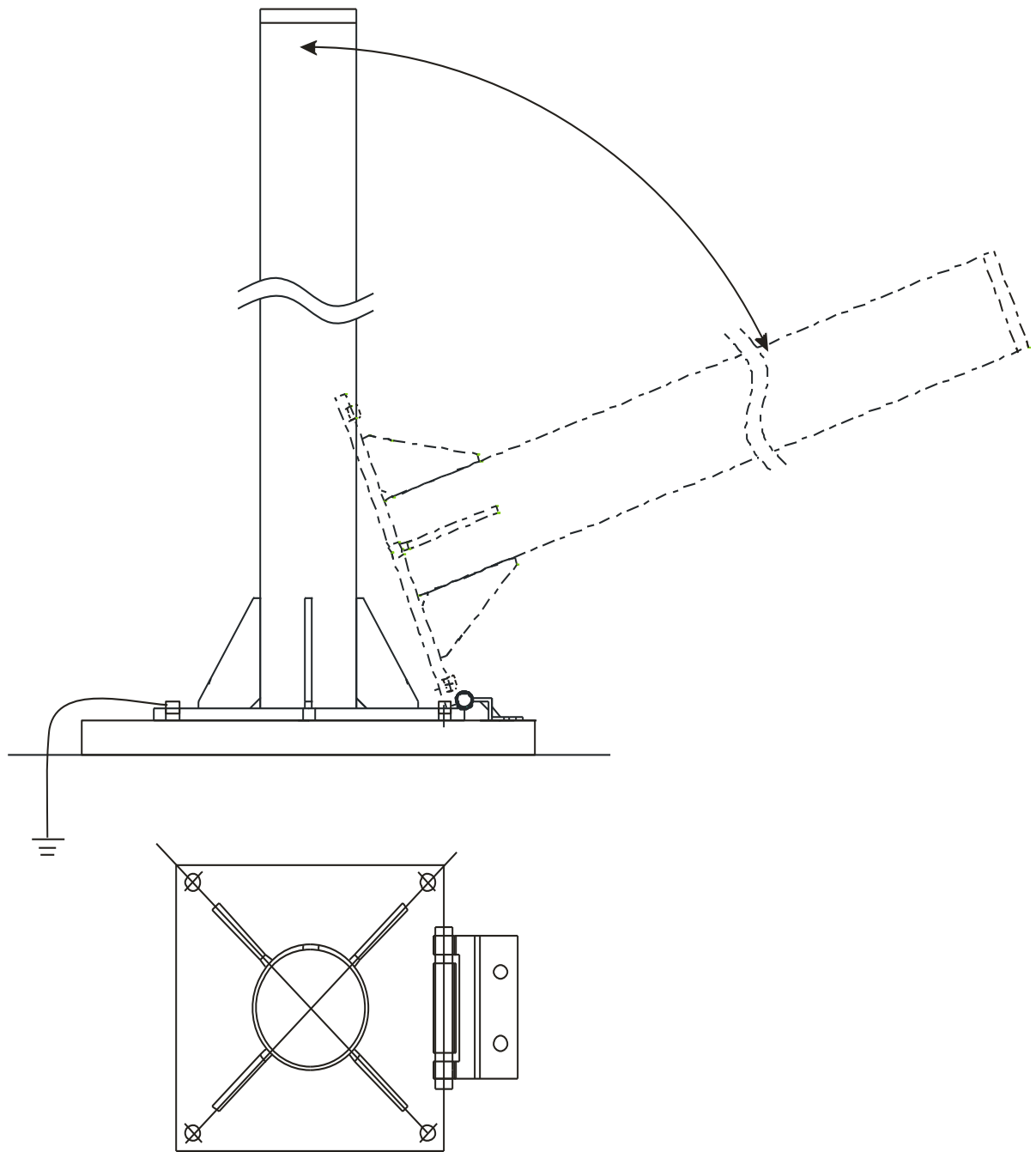

### **3.3 Foundation Guide for DS-300**

Before constructing the foundation for the DS-300 VAWT System, read these instructions carefully. These instructions are only intended to be a guide for concrete foundations on solid soils or



suitable roof infrastructure. Please contact your local civil or structure engineer for more information.

### **3.3.1 Ground Foundation**

The foundation should be prepared as 1 cubic meter in dimension (1000m/m x 1000m/m x 1000m/m) depth, dug into the soil. Please follow the diagram shown in the Figure 3-1, make a template of the mast bottom. This template will be temporarily used for holding four Anchor Bolts vertically and electrical conduit (if applied) in the precise position while pouring concrete into the foundation hole later.

Insert rebar into the foundation hole and jack up to approximately the right height. Prepare the electrical conduit in place before pouring the concrete if a hidden wiring method is applied. Attach the M16 screwed rods with nuts provided to the template, such that they will hang into the foundation hole from the template. Make sure there have at least 100mm of thread above the concrete level. Fix the conduit through the center of the template and push the other end of the conduit to the side of foundation (if applied).

Add the concrete, using a vibrating poker to remove air voids from the pour. It is very important to make sure the all four rods are hooked under the rebar. Once the concrete is all poured, make sure that the template has no air voids directly underneath. More importantly, make sure the template is leveled off.

Next, clear excess concrete from above the template and use a suitable cover to prevent the foundation from rain. Wait until the

concrete has set completely before removing the template ( It will take at least for one week ) .

Just remember, a solid with perfect leveled foundation is one of the key factors to achieve the success of the installation.

Please refer to the Figure 3-3 for DS-300 foundation construction.

**Figure 3-3 Ground Foundation Construction Reference**

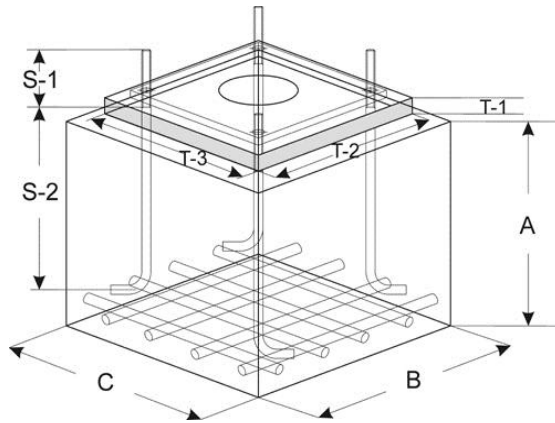

**Dimension Chart**

<b>A</b>	1 meter	
<b>B</b>	1 meter	
<b>C</b>	1 meter	
<b>T-1</b>	30mm	Concrete
<b>T-2</b>	400mm	Concrete
<b>T-3</b>	400mm	Concrete
<b>S-1</b>	100mm	
<b>S-2</b>	200mm	

### ***List of Material Required***

1	1 Cubic meter of concrete – 35 Newton or better.
2	4-M16 with length of 360m/m galvanized Anchor Bolts. One end is bent into a hook shape.
3	4-M16 Nuts.
4	4 galvanized washers.
5	Electrical conduit, 100m/m diameter pipe or similar, maybe needed for underground wiring, if applied.

### **3.3.2 Roof Foundation**

Installation of the DS-300 VAWT System on the roof may be much easier than it is on the ground. But special thought of the building structure has to be carefully taken into account before the installation.

We strongly suggest that the location on top roof surface should be above the concrete beam. Any surface other than concrete, the users should contact their own architect or structure engineer for advice and take their own responsibility for any possible dangers.

The concrete roof should be thick enough to allow 100mm drilling down from the surface. Please follow the template explained in Section 3.3.1 and use this template as a guide and drill four  $\varnothing 20$  holes 100mm deep down to the surface. Insert and secure four threaded rod to each hole, use 4mm plywood to make a square holding template with inner dimension T1 x T2 x T3, pour the concrete into this square template, then put the first template on top of the square

template to hold four rods temporarily before the concrete set completely and keep the surface leveled.

**Figure 3-4 Foundation for Roof Installation Reference**

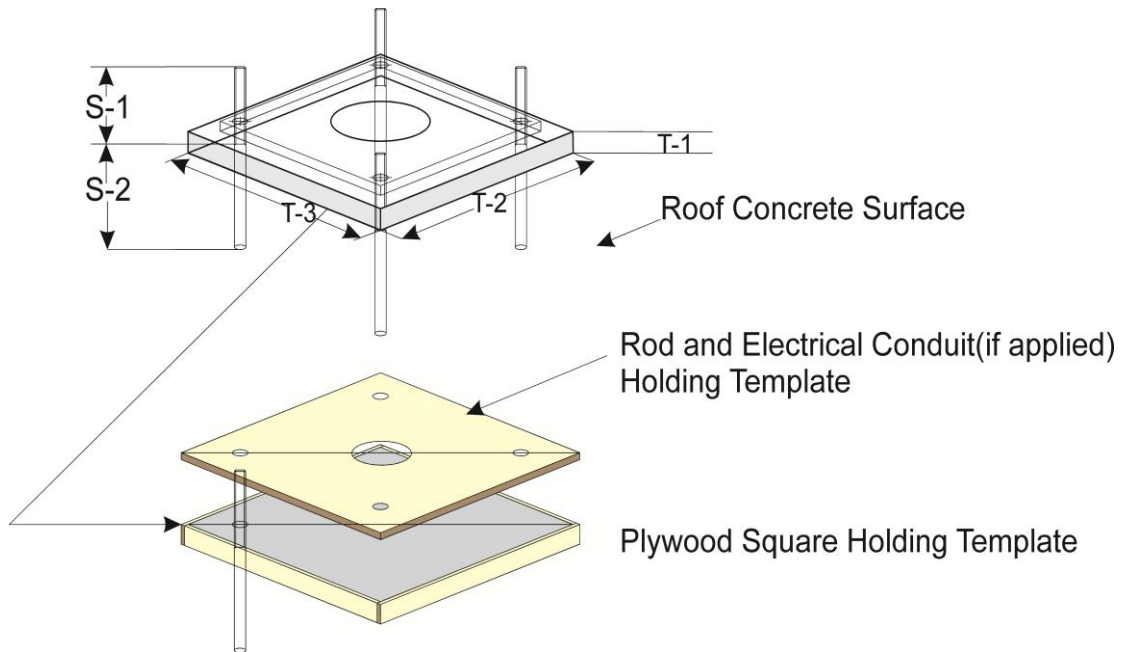

**Dimension Chart**

T-1	30 mm	
T-2	400 mm	
T-3	400 mm	
S-1	60 mm	
S-2	100 mm	

**⚠ WARNING**

- Although, the DS-300 VAWT System is designed to be installed on the roof alternatively, but Hi-VAWT does not recommend to

do so unless you are 100 percent sure that the structure of the building is capable of doing so.

- Please consult your local structural engineer and carefully evaluate such implementation before taking any further actions.
- It is user's responsibility to make sure that the structure of the building is able to sustain the force of operating DS-300 Wind Turbine System on the roof. Hi-VAWT is not responsible for any potential damage or dangerous factors caused by insufficiency of structural design of the building.
- Please closely follow your local government's regulations regarding related issues if you are going to install DS-300 on the roof.
- If you are going to install the DS-300 on the ground level, please consult your local civil engineer and carefully evaluate the nature of the soil and design of the foundation accordingly.

## 4. DS-300 Assembly and Installation

Before starting the assembly and installation of the DS-300 Wind Turbine System, please well prepare all required tools to complete the assembly and installation.

### 4.1 Tools Required for Assembly and Installation

As the DS-300 is factory pre-assembled, only a few tools required for finishing entire assembly and installation. We are strongly recommend having a crane with suitable capacity to haul up the mounting mast to desired location and also lift up the DS-300 to the mounting flange. Please refer to Figure 4-1 for your tool preparation.

*Figure 4-1 Required Tools for Assembly and Installation*



## CAUTION

- We strongly recommend you to prepare all suggested tools before proceeding the assembly and installation.
- Please always keep safety in mind while working on the assembly and installation.
- Preparing any extra equipments or safety devices accordingly if instructed by your local authority.

### 4.2 DS-300 VAWT Assembly

There are only a couple of steps to assemble the DS-300. Please follow the Figure 4-2, 4-3 and 4-4 *DS-300 Assembly Procedures* to complete the assembly.

*Figure 4-2 DS-300 Assembly Procedures - 1*

**DS-300**

*Assembly Procedures (Step 1)*

3 sets of M10 x 25mm Hex Head Bolts/Lock Nuts and 1 set of M8 x 25mm Hex Bolt/Lock Nut (Upper Blade Connector)

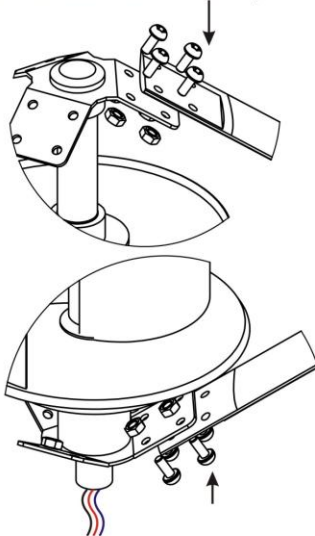

3 sets of M10 x 25mm Hex Head Bolts/Lock Nuts and 1 set of M8 x 25mm Hex Bolt/Lock Nut (Lower Blade Connector)

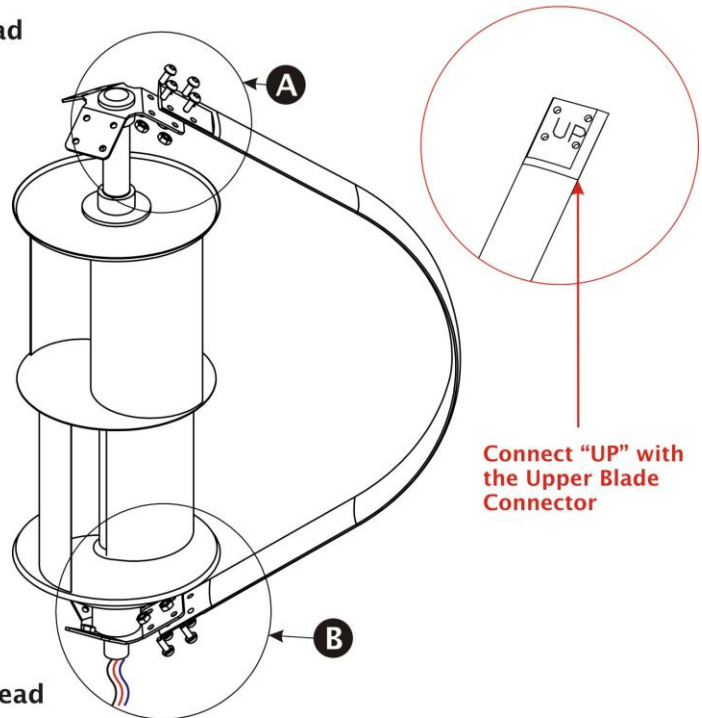

Insert 3 M10 x 25mm Hex Head Bolts/Lock Nuts and 1 M8 x 25mm Hex Head Bolt/Lock Nut for each one of the blades on the upper blade connector. Do not lock these four bolts yet until another 3 sets of M10 x 25mm Hex Head Bolts/Lock Nuts and 1 set of M8 x 25mm Hex Head Bolt/Lock Nut inserted for Lower Blade Connector. Now use Wrench to securely lock blade on upper blade connector and lower blade connector. Repeat this step for second blade and third blade and lower section as well.

The alignment of both upper blade connector and lower blade connector has been factory pre-lined up.

### **CAUTION**

- Each blade has a mark of “UP” on one side, please connect the “UP” end with the upper blade connector. Do not connect “UP” end with lower blade connector.
- If you are not able to see the “UP” mark on the blade, you may find three M10 holes and on M8 hole on both blade and connecting plate, just matching up each hole so you won't assemble the blade with wrong direction.

### **WARNING**

- For safety concern, please short circuit the RST Generator Wiring Cables temporarily to stop the rotor from rotation.



Figure 4-3 DS-300 Assembly Procedures - 2

**DS-300**

Assembly Procedures (Step 2)

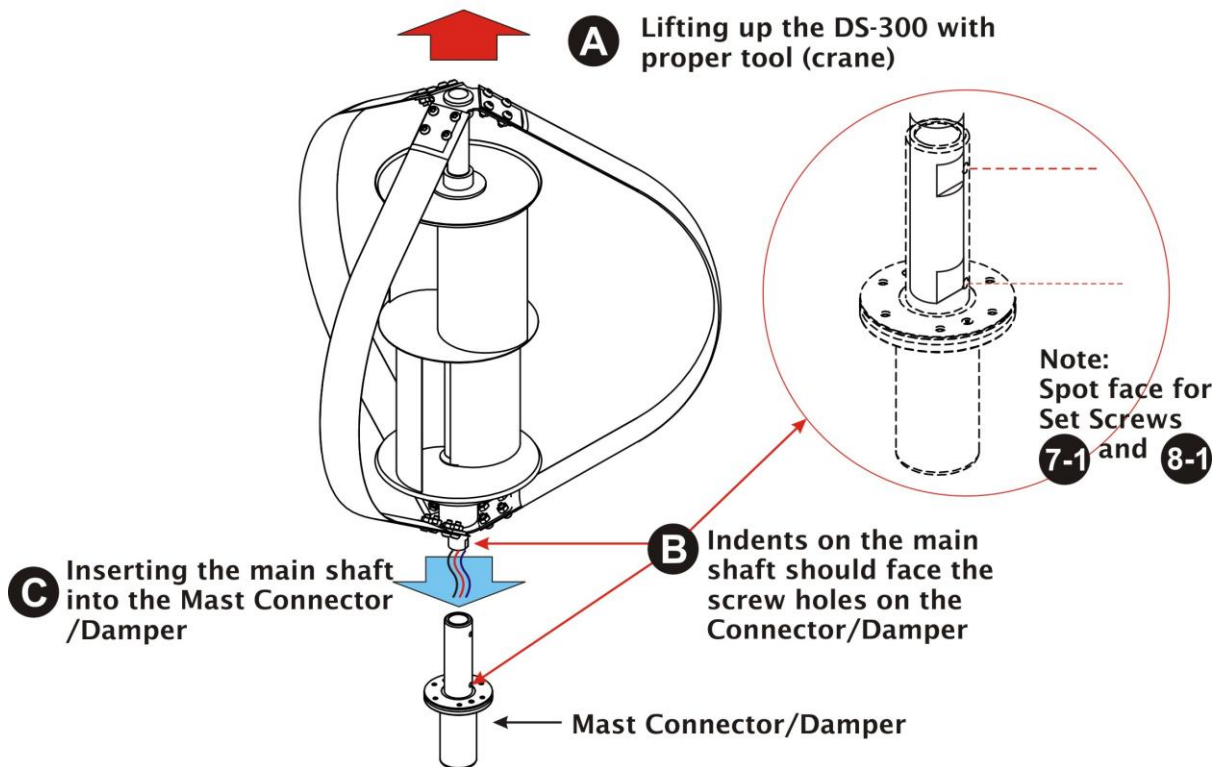

Make sure that all three blades have been securely locked on both upper blade connector and lower blade connector. Next step is to assemble the DS-300 VAWT System with the Mast Connector/Dumper.

Please use proper lifting device, such as crane, to lift the DS-300 up to the height that enough to put the Mast Connector/Damper under the main shaft of the DS-300, then insert the main shaft into the Mast Connector/Damper. There are two indents on the lower main shaft and should be lined up with two lock screw holes on the Mast Connector/Damper.

**⚠ WARNING**

- Indents on the lower main shaft must be lined up with lock screw holes on the Mast Connector/Damper and securely

locked. Fail to do so will cause the generator cables broken during break applied.

*Figure 4-4 DS-300 Assembly Procedures - 3*

**DS-300**

*Assembly Procedures (Step 3)*

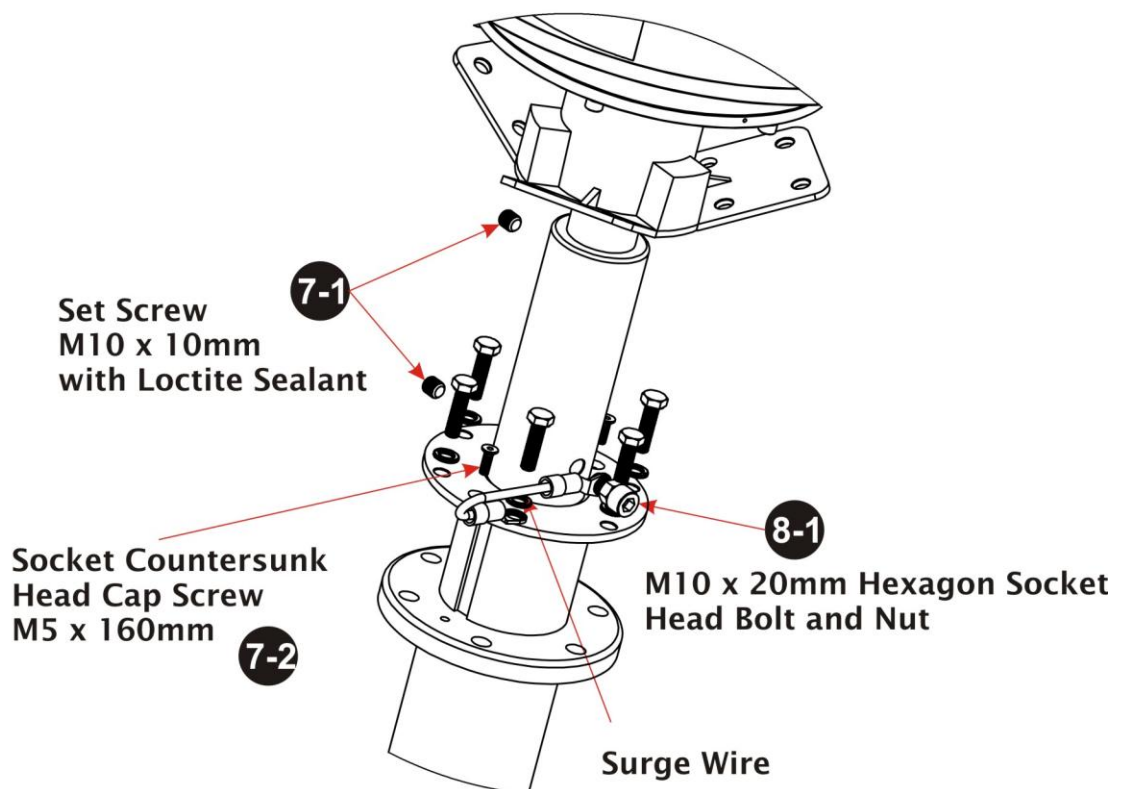

Use the M10 x 10mm Hexagon Socket Screw to lock the upper hole and M10 x 20mm Hexagon Socket Head Bolt and Nut to secure lower section with the surge wire.

### 4.3 DS-300 Installation

#### **WARNING**

- Double check with assembly procedures and make sure all screws are securely locked. Any loosen screw will cause serious vibration and parts damaged.

- If you are going to install the DS-300 VAWT System at certain height, please have proper safety devices ready for proceeding installation.

*Figure 4-5 DS-300 Installation Procedures - 1*

**DS-300** *Installation Procedures (Step 2)*

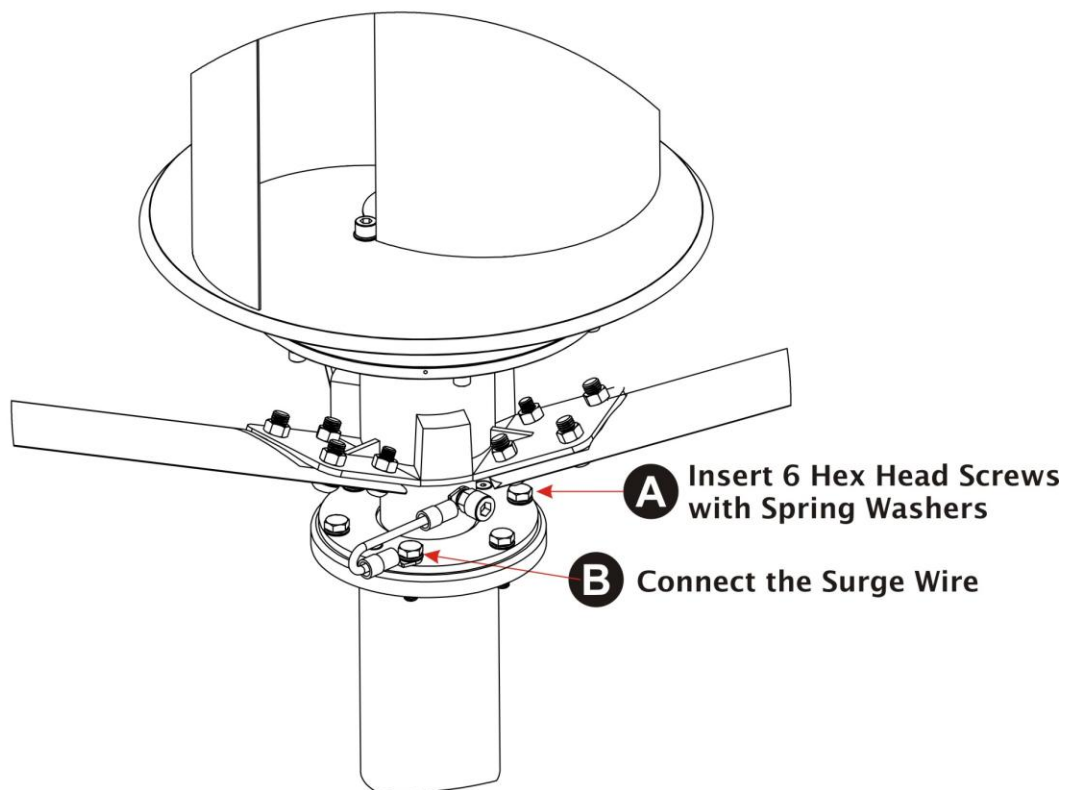

In Figure 4-5, please insert 6 Hex Head Screws with Spring Washers and connect the Surge Wire under one of the washers.

Figure 4-6 DS-300 Installation Procedures - 2

**DS-300**

*Installation Procedures (Step 2)*

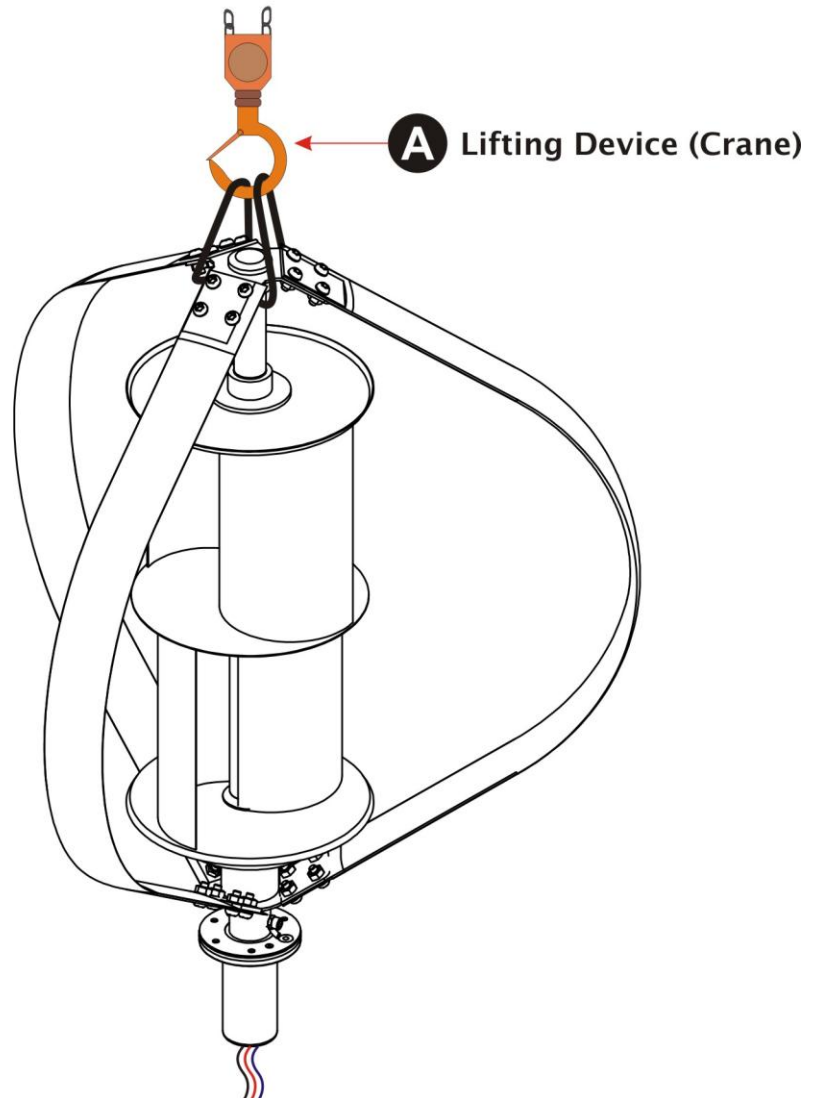

Use proper lifting device (Crane) to lift up the DS-300 above the mast flange.

 **NOTE**

- There are 3 proper size of wires should be pre-installed inside the Mast
- Securely connect the RST Generator Wires with these 3 pre-installed wires.

Figure 4-7 DS-300 Installation Procedures - 3

**DS-300**

*Installation Procedures (Step 3)*

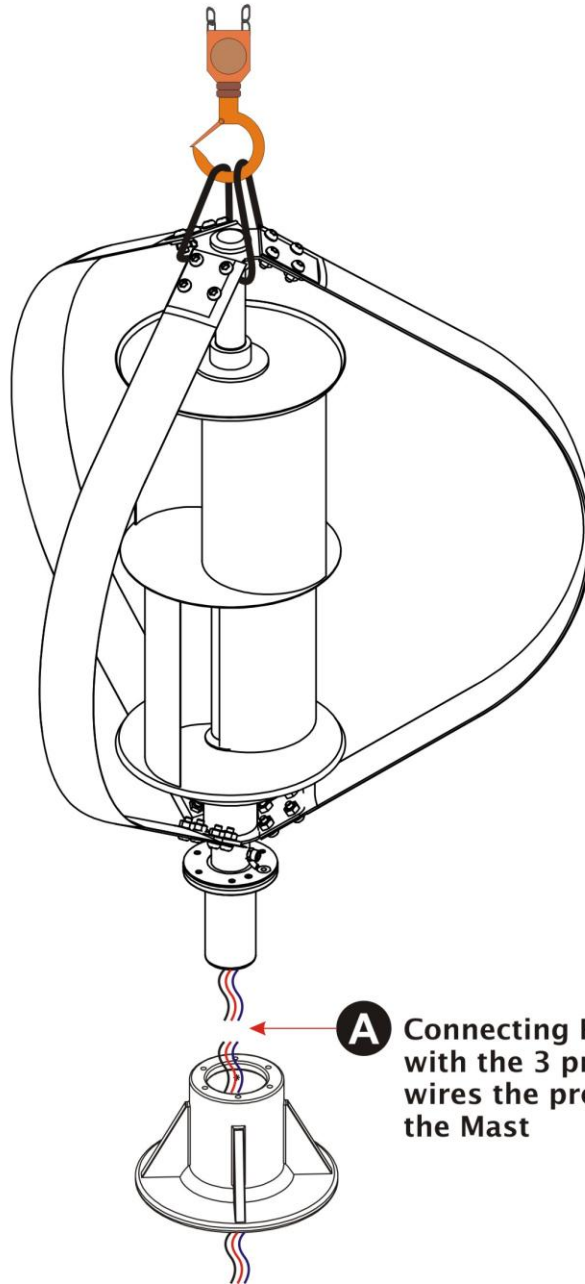

 **NOTE**

- Please refer to the Chapter 5 Wiring section for detail.

*Figure 4-8 DS-300 Installation Procedures - 4*

**DS-300**

*Installation Procedures (Step 3)*

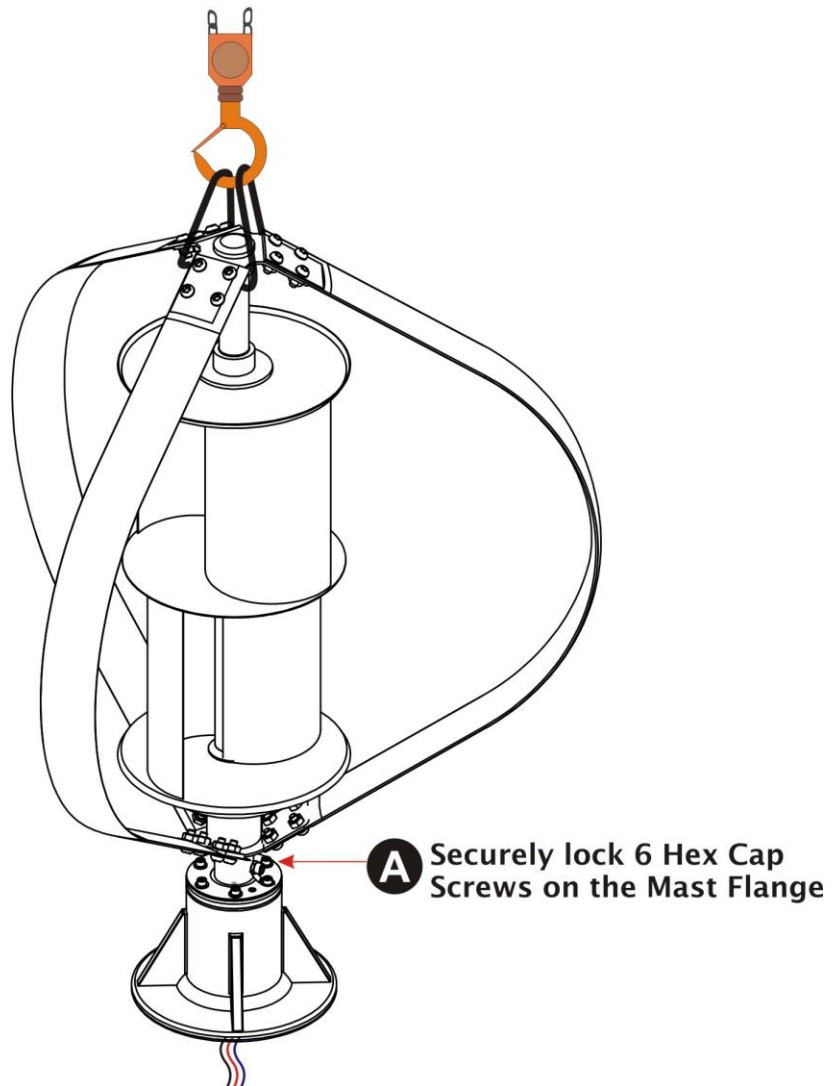

Vertically insert the DS-300 into the Mast, and then securely lock Mast Connector/Damper with the Mast Flange by 6 Hexagon Socket Screws.

After the completion of this step, you have finish the DS-300 Wind Turbine System and ready for further wiring procedures.

## 5. Wiring

### 5.1 General Information

Please refer to all local and national codes or special regulations to be followed before installation. All works on the electrical system like installation, maintenance, and repair should be carried out by qualified technicians and make sure that they read all technical information and instructions contained in related manuals.

The wiring diagram should be planned ahead and make sure all required wiring components are well prepared accordingly.

#### CAUTION

- Carefully plan all required electrical components, and install electrical components first before any electrical connection.
- Make sure that batteries (if applied) should be disconnected all installation works are completed.
- All electrical power cables should be physically protected. Run the wires inside the mast of conduit for maximum protection.

### 5.2 DS-300 Wire Size

The cross section of the wire to be used depends on its length, resistance and rated current. All electrical systems lose energy from the resistance of the wire used. Larger wire size has smaller losses, but can be considerably more costly.

Closely look at the site that the DS-300 VAWT System is to be installed and measure the following distances:

- Distance between DS-300 VAWT and the location of DS-300 Controller.
- Distance between the solar panel and the DS-300 Controller.
- Distance between the photodiode and the DS-300 Controller.
- Distance between the DS-300 Controller and the Battery. It is recommended that the length between DS-300 Controller and Battery is no longer than 5 meters.

Please follow the reference table below for wire sizing:

***Table 5-1 Wire Sizing Reference***

Distance Between Generator and Controller					
	0-10m	10-20m	20-30m	30-50m	>50m is not suggested.
AWG Gauge	12	12	10	8	

### 5.3 DS-300 Wiring Diagram

The DS-300 VAWT System is designed in collaboration with WG0400 Wind Charge Controller and WG0400/RC10-II Wind/PV Hybrid Controller. Both wiring diagrams will be illustrated in Figure 5-1 and Figure 5-2.

#### **WARNING**

- Hi VAWT Technology Co., Ltd. makes no warranty that DS-300 Wind Turbine System will work with power management devices other than WG0400 and WG0400/RC10-II in terms of performance and functionality.



**Figure 5-1 Wiring Diagram for Wind Charge Controller (WG0400)**

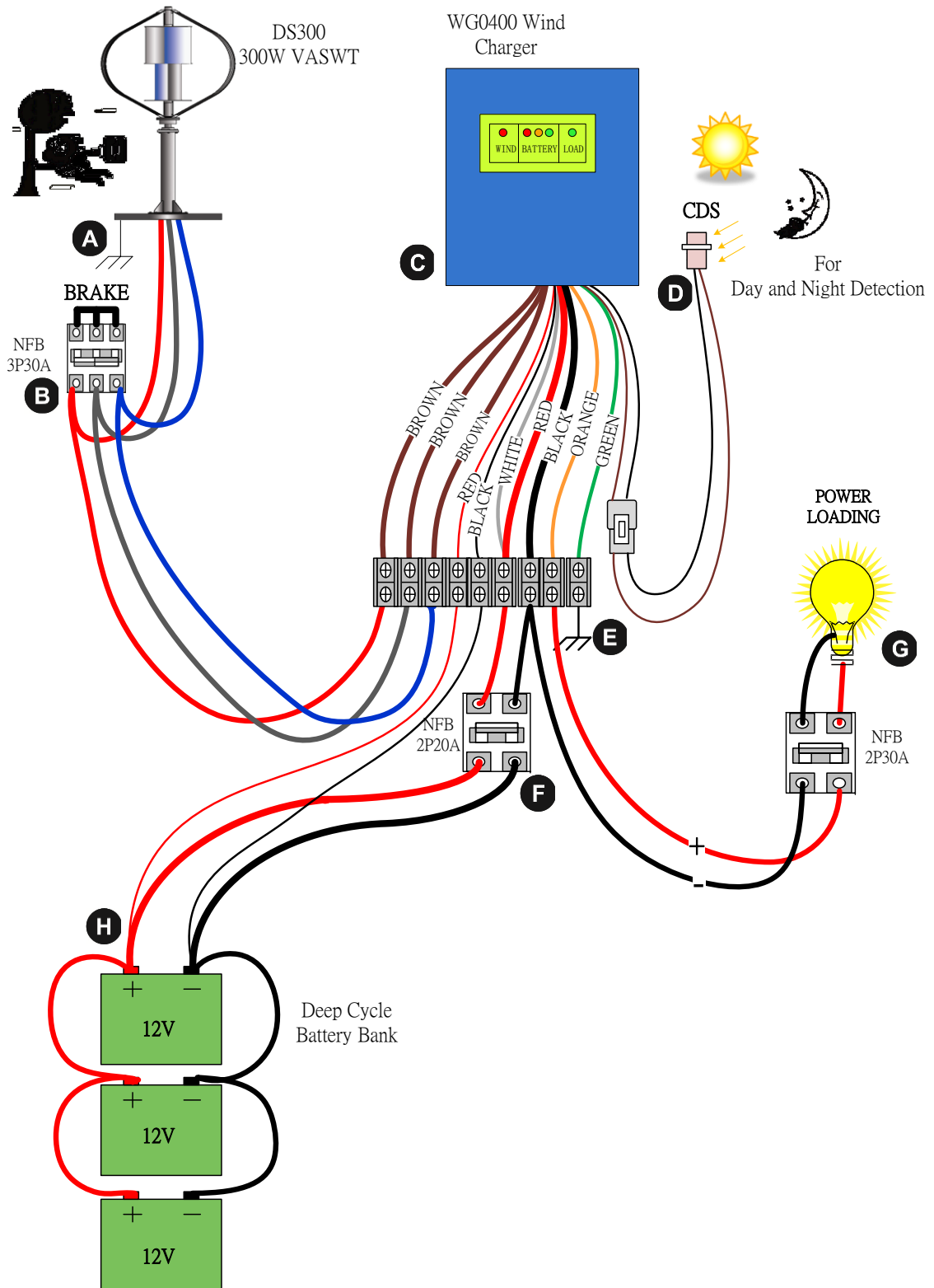

**Table 5-2 DS-300 Wiring Size Reference (WG0400)**

Description		Wire Size
<b>A</b>	Mast Ground	AWG#12
<b>B</b>	Stop Switch (≥125VAC/30A) Connection	AWG#12
<b>C</b>	Wind Charge Controller (WG0400)	
<b>D</b>	Photo Diode	AWG#18
<b>E</b>	Wind Charge Controller Ground	AWG#12
<b>F</b>	Fuse or Circuit Breaker (50Amps DC)	AWG#10 (Within 5 Meters)
<b>G</b>	DC Loading	AWG#12
<b>H</b>	Deep Cycle Battery (DC12V/100Ah~250Ah)	

 **NOTE**

- Please refer to the WG0400 Wind Charge Controller User's Manual for further information.

**Figure 5-2 Wiring Diagram for Wind/PV Hybrid Controller (WG0400/RC10-II)**

**DS-300**

*Wiring Diagram (WG-0400/RC10-II)*

**WG-0400(12V/24V)/RC10-II Hybrid Charger Wiring Diagram**

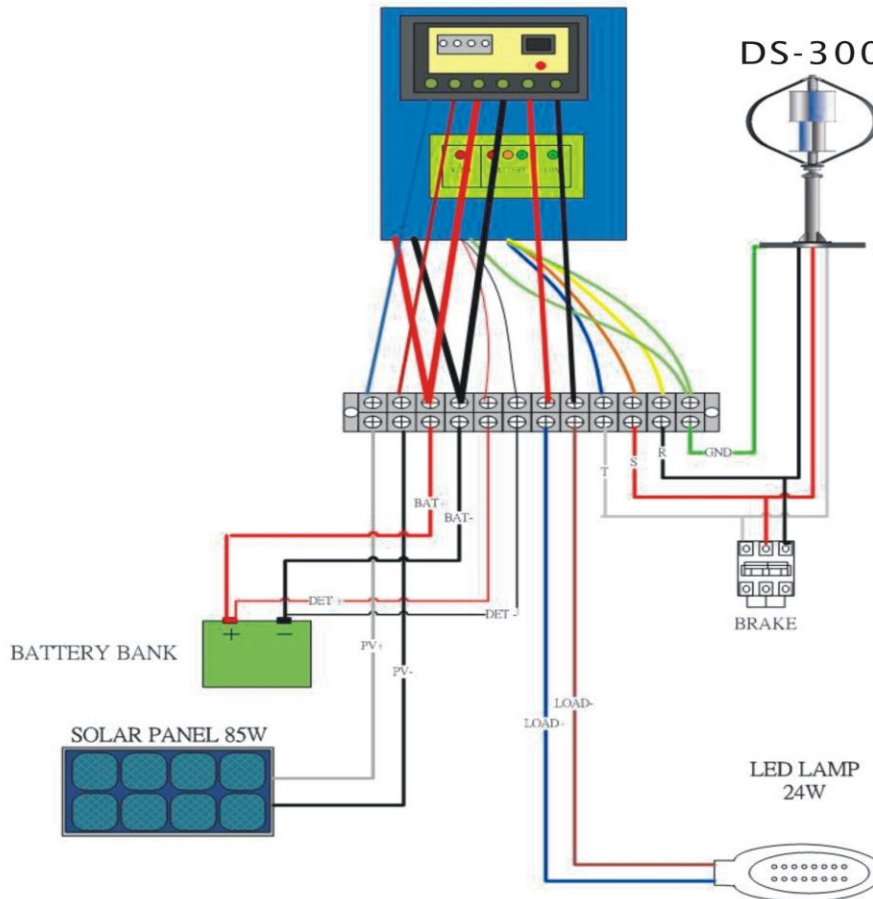

**NOTE**

- Please refer to the WG0400/RC10-II Wind Charge Controller User's Manual for further information.

## 5.4 PV Charging

To charge 12V battery bank, the PV charger is available for PV panel which the voltage reaching between 12V and 50V. Please note that the charger will not be available if the voltage of solar panel is lower than 24V when charging for 24V battery bank.

## 5.5 Grounding

In order to protect the DS-300 Wind Turbine System against damage by lightning, static or over voltage, properly grounding the DS-300 Wind Turbine System is very important. Grounding procedures must be followed along with any local electrical codes.

The design of the grounding system depends on the local conditions, like the site of the installation, type of soil, or a grounding bus already existing. If you are in doubt, contact your local electrician for more information.

### **WARNING**

- SEVERE TURBINE DAMAGE CAN RESULT FROM IMPROPER GROUNDING!
- FAILURE TO PROPERLY GROUND WILL VOID THE WARRANTY.

## 5.6 Fusing

To protect the battery against short circuit, fuse must be installed in the positive line between the Controller and Battery. The recommended fuse type is 50amp DC Slow-Blow fuse for 12V system or appropriate automatic circuit breaker.

The fuse must be placed as close to the battery as possible, however, not in the same compartment. Unsealed lead-acid batteries have vent holes releasing hydrogen which forms

detonating gas with the ambient air. A spark when blowing the fuse (or releasing an automatic circuit breaker) can detonate the explosive mixture.

## **5.7 Stop Switch**

A Stop Switch must be used with the DS-300 Wind Turbine System. This Stop Switch is installed between the DS-300 Wind Turbine and the Controller to provide a convenient method for remotely and manually shutting down the DS-300 turbine. This Stop Switch disconnects the Controller then short-circuits the turbine causing the turbine to stop spinning.

A Triple Pole Double Throw (TPDT or 3PDT) should be used for a 3 phase wind turbine generator equipped with the DS-300.

## 6. Warranty

The Hi VAWT Technology Corporation (Hi-VAWT) provides one (1) year limited warranty (Warranty Period) for products it manufactures and covers defects in materials, workmanship and quality (Defeats) in the DS-300 VAWT System. The warranty is valid from the date of invoice to the original user. The limited warranty is also transferable and applied to subsequent owners only within the Warranty Period.

Hi VAWT will repair or replace the defective products for free under the following conditions:

- The user has notified Hi-VAWT of the Defeat within the Warranty Period.
- Hi-VAWT verifies the existence of a Defeat that is covered within the limited warranty by its inspection, troubleshooting and any possible mean to identify.
- Shipping cost from Hi-VAWT to user for replacement or repaired parts.

Hi-VAWT has the option to use new or reconditioned parts in performing repair or replacement. Hi-VAWT also reserves the right to use parts or improved design in the repair or replacement.

If you purchase the product from our dealer in your area, contact the dealer for repair or replacement or you may contact us directly at the following numbers:

Telephone: + 886 2 8601 4373

Fax: + 886 2 8601 1263

Email Address: [sales@hi-vawt.com.tw](mailto:sales@hi-vawt.com.tw)

Please provide the proof of purchase (dated invoice) for defective products repair or replacement.

The limited warranty does not apply to any product or part thereof damaged by the following conditions:

- Any alteration to the product either internally or externally, or disassembly of the product.
- Not been used in accordance with the User's Manual supplied with the product.
- Installed and used in an unsuitable environment.
- Operation or installation contrary to instructions pertaining to the product.
- Damaged during shipping, mishandled, neglected, improperly installed.
- Repair or service provided by an unauthorized repair facility.
- Lightning strikes without proper grounding.

Hi-VAWT does not warrant or guarantee the workmanship performed by any person or firm installing its products.

HI VAWT MAKES NO WARRANTY AS TO THE ACCURACY, SUFFICIENCY OR SUITABILITY OF ANY TECHNICAL OR OTHER INFORMATION PROVIDED IN MANUAL OR OTHER DOCUMENTATION PROVIDED BY IT IN CONNECTION WITH THE PRODUCT.

ASSUMES NO RESPONSIBILITY OR LIABILITY FOR LOSSES, DAMAGES, COSTS OR EXPENSES, WHETHER SPECIAL, DIRECT, INDIRECT,

CONSEQUENTIAL OR INCIDENTAL, WHICH MIGHT ARISE OUT OF THE USE OF SUCH INFORMATION.

THE USE OF ANY SUCH INFORMATION WILL BE ENTIRELY AT THE USER'S RISK.

 **WARNING Limitations on Use**

Please Note, the Hi-VAWT's DS-300 VAWT System is not intended for use as the power source of life support systems or other medical equipment or devices and Hi-VAWT makes no representation or warranty in connection with any use of the product for such purposes.







P/N:   
DS 0 3 - U M E N - 0 0 - 2

S/N:   
201006101210

Hi-VAWT Technology Corporation  
[www.hi-vawt.com.tw](http://www.hi-vawt.com.tw)  
No. 168, Jhulin 1st Road.,  
Linkou Township,  
Taipei County 24443, Taiwan